

IRVING
HALIFAX
SHIPYARD

CANADA'S NATIONAL SHIPBUILDER

shipsforcanada.ca



BUILD YOUR OWN ARCTIC AND OFFSHORE PATROL SHIP

A classroom activity for future shipbuilders

Irving Shipbuilding

It's an exciting time to be a shipbuilder in Canada. Major shipbuilding programs are underway as part of the Government of Canada's National Shipbuilding Strategy to replace the current fleets of ships for the Royal Canadian Navy and the Canadian Coast Guard. This work is revitalizing Canada's shipbuilding industry and creating jobs and business opportunities across the country.

As part of the National Shipbuilding Strategy, Irving Shipbuilding's Halifax Shipyard is constructing 21 modern combat vessels for the Royal Canadian Navy,

six Arctic and Offshore Patrol Ships (AOPS) and 15 Canadian Surface Combatants (CSC). The first AOPS, the largest navy ship built in Canada in 50 years, was launched in 2018. Construction of the first CSC, the future backbone of the Royal Canadian Navy, will start in the mid-2020s with additional ships being built for decades to come.

Shipbuilding provides exciting, hands-on, and technology driven careers. Are you part of the next generation of Canadian shipbuilders?



Build Your Own AOPS

Shipbuilding Careers

- Ironworker/Metal Fabricator
- Welder
- Pipefitter
- Electrician
- Painter
- Boilermaker
- Naval Architect
- Mechanical Engineer
- Industrial Engineer
- Supply Chain Manager
- Quality Control Inspector
- Project Manager
- Health and Safety Officer
- Process Manager
- Manufacturing Engineer
- Combat Systems Engineer
- Materials Manager
- And many more!



Thanks to the Irving Shipbuilding team, Cortney Banks, Kayla Jackman, James Brunelle, Adele Scott, and Joe McCarthy for their expertise and imagination developing this activity.

ADDITIONAL RESOURCES:
shipsforcanada.ca
otcns.ca/careers
techsploration.ca/videos

Canada's Arctic and Offshore Patrol Ships

Irving Shipbuilding uses a progressive build approach to construct Canada's Arctic and Offshore Patrol Ships – the most efficient process for building modern ships. Over the course of time, 63 smaller units become 21 larger blocks, which become three mega-blocks (the bow, centre and stern). This same progressive build approach will be used for the Canadian Surface Combatants.

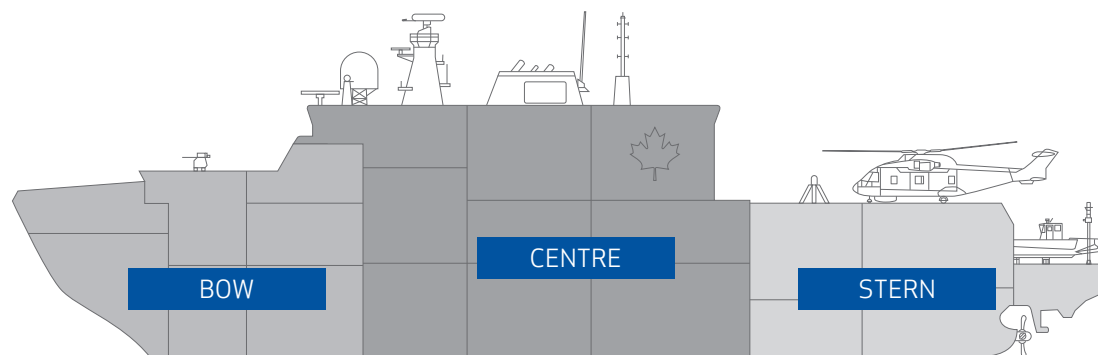

Overview

Shipbuilding is a team effort at Irving Shipbuilding's Halifax Shipyard. It requires focus, precision, communication and cooperation from shipbuilders in many different roles working together to build the Royal Canadian Navy's future fleet.

Using some of the latest technology combined with traditional manufacturing, the Halifax Shipyard team of welders, pipe-fitters, electricians, designers, engineers, quality inspectors, accountants, supply chain managers, and many more are working together everyday to maintain and repair Halifax-class frigates, and build new Arctic and Offshore Patrol Ships, and Canadian Surface Combatants. Now your class can build the STEM-class of ships.

Members of the Irving Shipbuilding team have worked hard to develop this activity to mimic the process of shipbuilding on a small scale and inspire future shipbuilders. We encourage you to visit shipsforcanada.ca to watch updated videos of the latest progress at Halifax Shipyard.

This activity was developed in partnership with the Centre for Ocean Ventures and Entrepreneurship (COVE) coveocean.com. Irving Shipbuilding is proud to support COVE with over \$6 million in National Shipbuilding Strategy Value Proposition investments for workforce related research, programs, and activities, as well as operational and program support to benefit small businesses in the ocean sector in Canada.



Rationale

This workshop is designed to combine technical skill building, reading engineering documents, and following exact direction as students participate in a collaborative problem-solving exercise. The goal is to simulate advanced manufacturing methods and materials management in a modern shipbuilding facility, demonstrating different career paths including skilled trades like welding, engineering, and project management. Students should produce the same end product by interpreting and following the same set of directions.

THIS ACTIVITY INVOLVES:

- Reading authentic technical drawings (designed by a team of engineers from Irving Shipbuilding)
- Material cutting and shaping (to mimic metal fabrication)
- Gluing (to mimic welding), and assembly of mega-blocks into a ship's hull

We encourage you to visit shipsforcanada.ca to see updated photos and videos of progress at Halifax Shipyard.

Problem Scenario

BUILDING CANADA'S NEXT FLEET

In order to deliver the best ships to the Navy, and provide the best value to Canadian taxpayers, ships need to be built exactly as the technical drawings outline, on time, and on budget. These ships need to be completed to the best quality (water tight, stable, etc.) in the shortest amount of time, with the least amount of wasted materials.

Teams are encouraged to decide how best to tackle the project, by assigning specific tasks to each person (i.e. cutter, gluer, project manager, etc.) or by each individual assuming all of these roles for a single section, and then bringing the sections together. You can track progress by timing, finished product, and material used. If you assign a 'cost' to materials, you can try to work within a set budget.

This activity has strong curricular connections with technology education, reading and interpreting technical drawings, translating 2-D drawings into a 3-D model, and investigating connections between technology education and careers.

SUCCESS DETERMINANTS

- Students have demonstrated that they have successfully followed the technical drawings
- The final product looks like the intended design
- The structure floats for an extended period including when weight is added, without taking on water
- Students reflect on what did and didn't work and where improvements can be made

PARAMETERS

- Divide students into groups of 3-5
- Students must work together and communicate to determine various roles and responsibilities among their groups
- Give students an allotted amount of time to complete the activity. 1 hour is recommended. If the plastic sheets are pre-cut the activity can be done in 30 min.
- Students must research how ships are named, and properly name their structure

ACTIVITY EXTENSIONS

- **Careers.** Have students work in assigned roles throughout the project. Research the different careers and present back on how they contributed to the overall construction and assembly (ex. welder, pipefitter, naval architect, project manager)
- **Project Management.** Include financial management by assigning prices to the materials, and a labour cost (per 10 minutes of labour), and a target budget and build time for students to work towards. Students are to build their structure with the least amount of waste and lowest possible budget. Any waste must be accounted for in the budget
- **Functionality.** Once the ship is assembled and launched, have students work to make it stable and balanced and able to carry an assigned load in the hull and on deck. Add requirements for the superstructure or deck use. Design and add a propulsion system
- **Reverse Engineer.** Build a simple vessel or structure in 'blocks' and then do drawings and work instructions for its construction and assembly. Can be done with uniform materials (i.e. lego) or non-uniform (i.e. recyclables, consumables)

Construction of Mega-Block 1

ACTIVITY

To construct the Stern Section of the STEM-class Ship - Mega-Block 1

NOTES

- Ensure optimal utilization of all materials to reduce waste
- Ensure all cutting surfaces are protected when cutting materials with the use of a cutting board

MATERIAL REQUIREMENTS

- Permanent Marker
- Clear Ruler
- Exacto Knife
- Cutting Board
- Foam Board
- Poly Covers or Plastic Sheets
- Scissors
- Glue Gun
- Duct Tape
- Canada Flag

DEFINITIONS

Bulkhead: a dividing wall or barrier between compartments in a ship

Deck: a structure approximately horizontal, extending across a ship

Longitudinal: situated along the length of the ship

Port: the left side of the ship

Shell: the outer most structure of a ship

Starboard: the right side of the ship

Stern: the back most part of the ship

Transverse: situated across the width of the ship

Superstructure: the part of the ship that rises above the hull

ACRONYMS

DWG: Drawing

FWD: Forward

LKG FWD: Looking Forward

LKG DWN: Looking Down

LKG PORT: Looking Port

PS: Port Side

STBD: Starboard

TYP: Typical, meaning the same on both sides

Construction of Mega-Block 1

STEPS

1.0 Stern-Transverse Bulkhead

1.1 Using Stern-Transverse Bulkhead drawing (p.10) measure, mark-up and cut out section of foam board using an exacto knife to the exact measurements stipulated on the drawing.

2.0 Stern-Longitudinal Bulkhead

2.1 Using Stern-Longitudinal Bulkhead drawing (p.11) measure, mark-up and cut out section of foam board using an exacto knife to the exact measurements stipulated on the drawing.

3.0 Stern-Deck

3.1 Using Stern-Deck drawing (p.12) measure, mark-up and cut out section of foam board using an exacto knife to the exact measurements stipulated on the drawing.

4.0 Stern-Shell

4.1 Using Stern-Shell drawing (p.13) follow the 'NOTES' section to mark-up, cut and fold poly covers or plastic sheets using scissors to the exact measurements stipulated on the drawing.

5.0 Stern-Assembly

5.1 Using Stern-Assembly drawing (p.14) follow the 'NOTES' section to assemble Transverse Bulkhead, Longitudinal Bulkhead, Deck & Shell to form Mega-Block 1.

5.2 Use glue gun to secure sections.

6.0 Mast-Assembly

6.1 Using Mast-Assembly drawing (p.15) measure, mark-up and cut poly covers or plastic sheets using scissors to the exact measurements stipulated on the drawing.

6.2 Follow the 'NOTES' section to create the circular section of the Mast.

6.3 Assemble as per drawing and use glue gun to secure.

6.4 Install flag as per drawing.

BILL OF MATERIALS		
NAME	QUANTITY	MATERIAL DESCRIPTION
STERN - TRANSVERSE BULKHEAD	1	0.5CM THICK FOAM BOARD

NOTES:

1. ALL DIMENSIONS IN CENTIMETERS

*DRAWING NOT TO SCALE

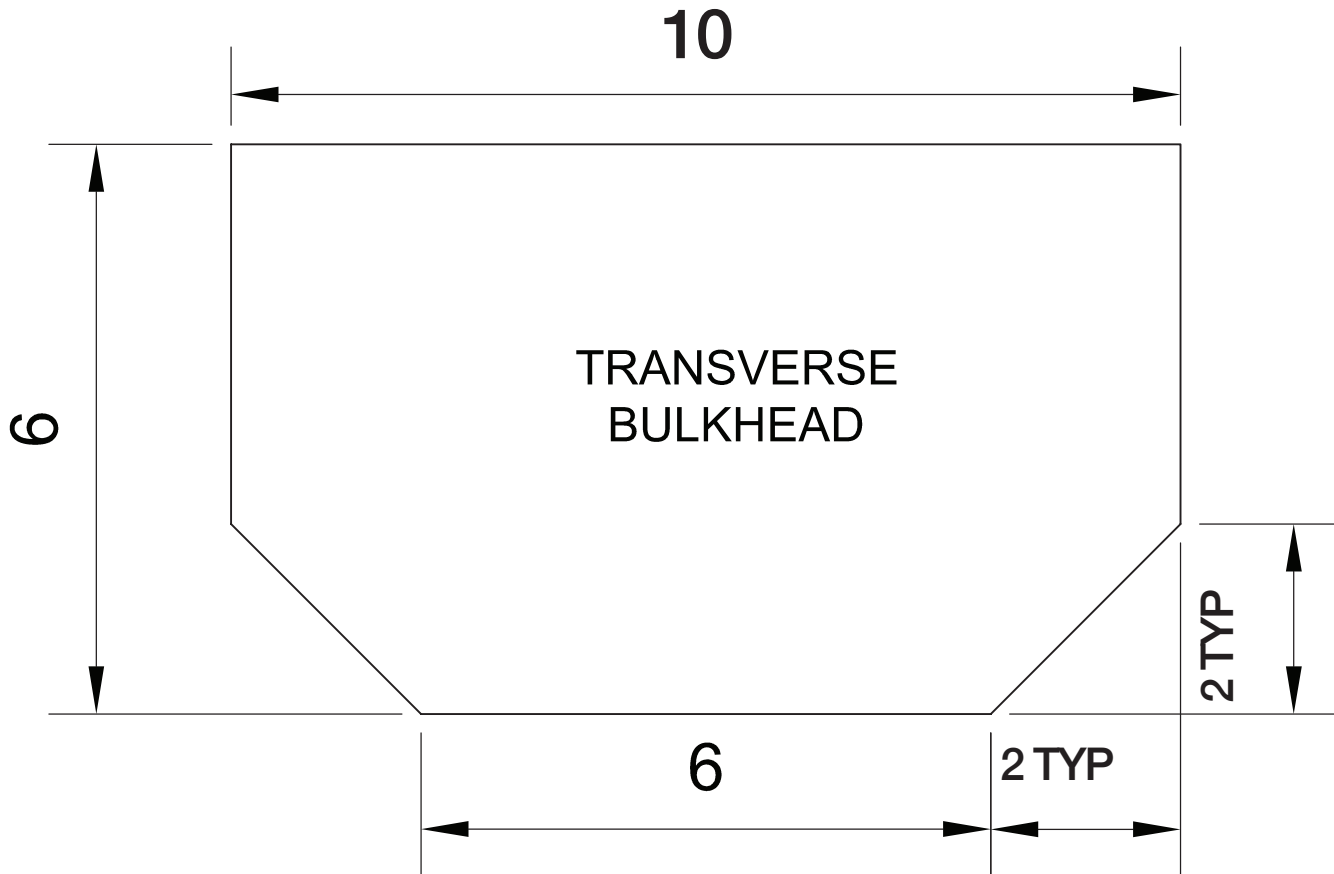

**SECTION
LKG FWD**

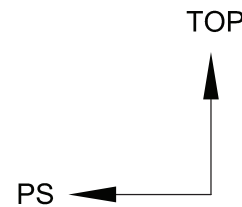

 STEM CLASS SHIP 1	FABRICATION DRAWING STERN - TRANSVERSE BULKHEAD MEGA BLOCK 1			
	DWN	K. JACKMAN	CHK	C.BANKS
	UNITS	CENTIMETRES	SCALE	NTS
	SHEET	1	DATE	2018-10-29
	DWG NO	A01-STERN PACKAGE-001		REV A

BILL OF MATERIALS		
NAME	QUANTITY	MATERIAL DESCRIPTION
STERN - LONGITUDINAL BULKHEAD	1	0.5CM THICK FOAM BOARD

NOTES:

- 1. ALL DIMENSIONS IN CENTIMETERS
- *DRAWING NOT TO SCALE

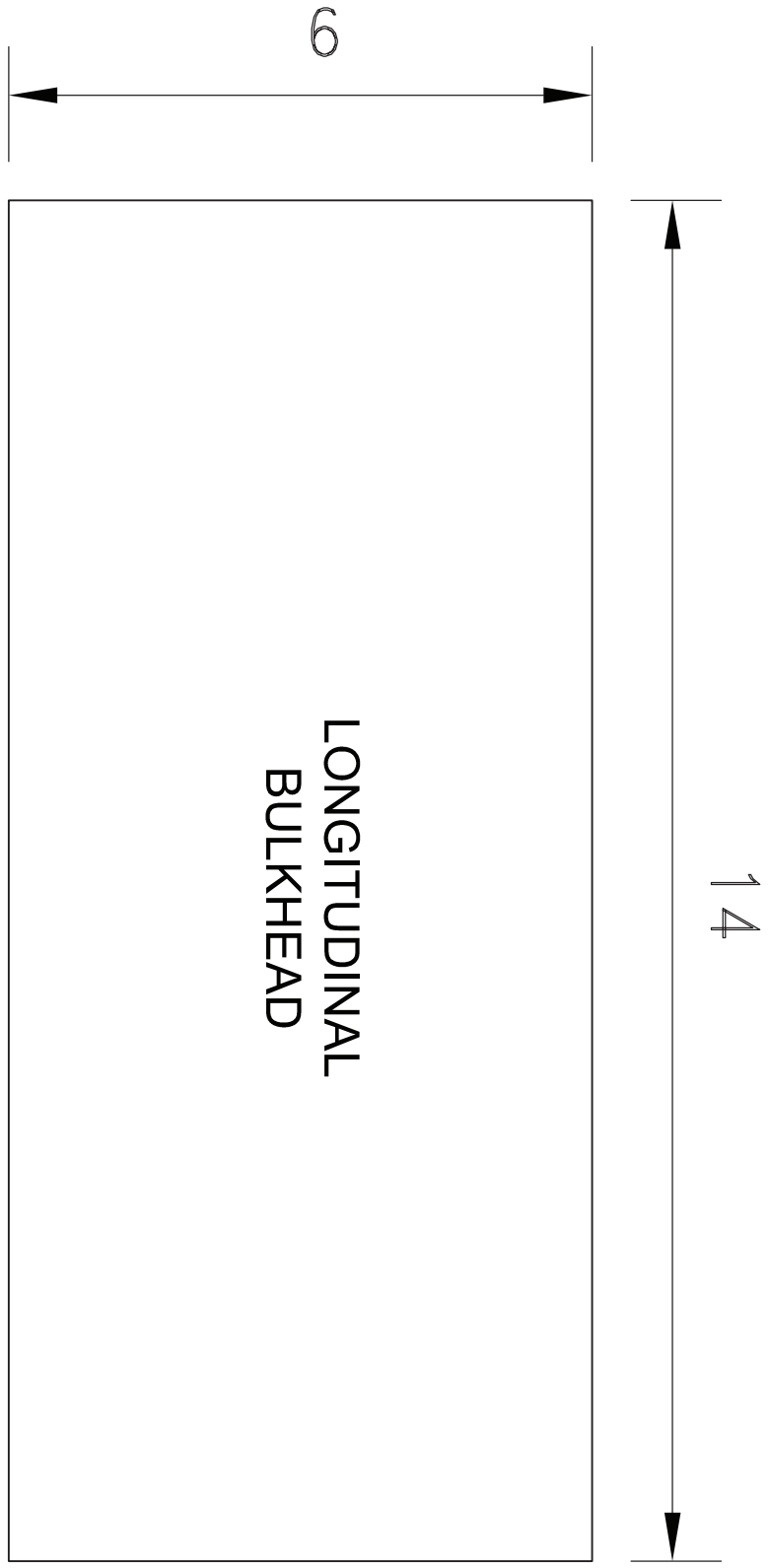

SECTION
LKG PORT

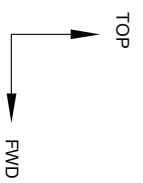

	FABRICATION DRAWING STERN - LONGITUDINAL BULKHEAD MEGA BLOCK 1			
	DRAWN	K. JACHMANN	CHK	C.BANKS
STEM CLASS	UNITS	SCALE	NTS	SIZE D
SHIP 1	SHEET 1	DATE	2018-10-29	REV' A
DWG NO		A01-STERN PACKAGE-002		REV' A

BILL OF MATERIALS		
NAME	QUANTITY	MATERIAL DESCRIPTION
STERN - DECK	1	0.5CM THICK FOAM BOARD

NOTES:
 1. ALL DIMENSIONS IN CENTIMETERS
 *DRAWING NOT TO SCALE

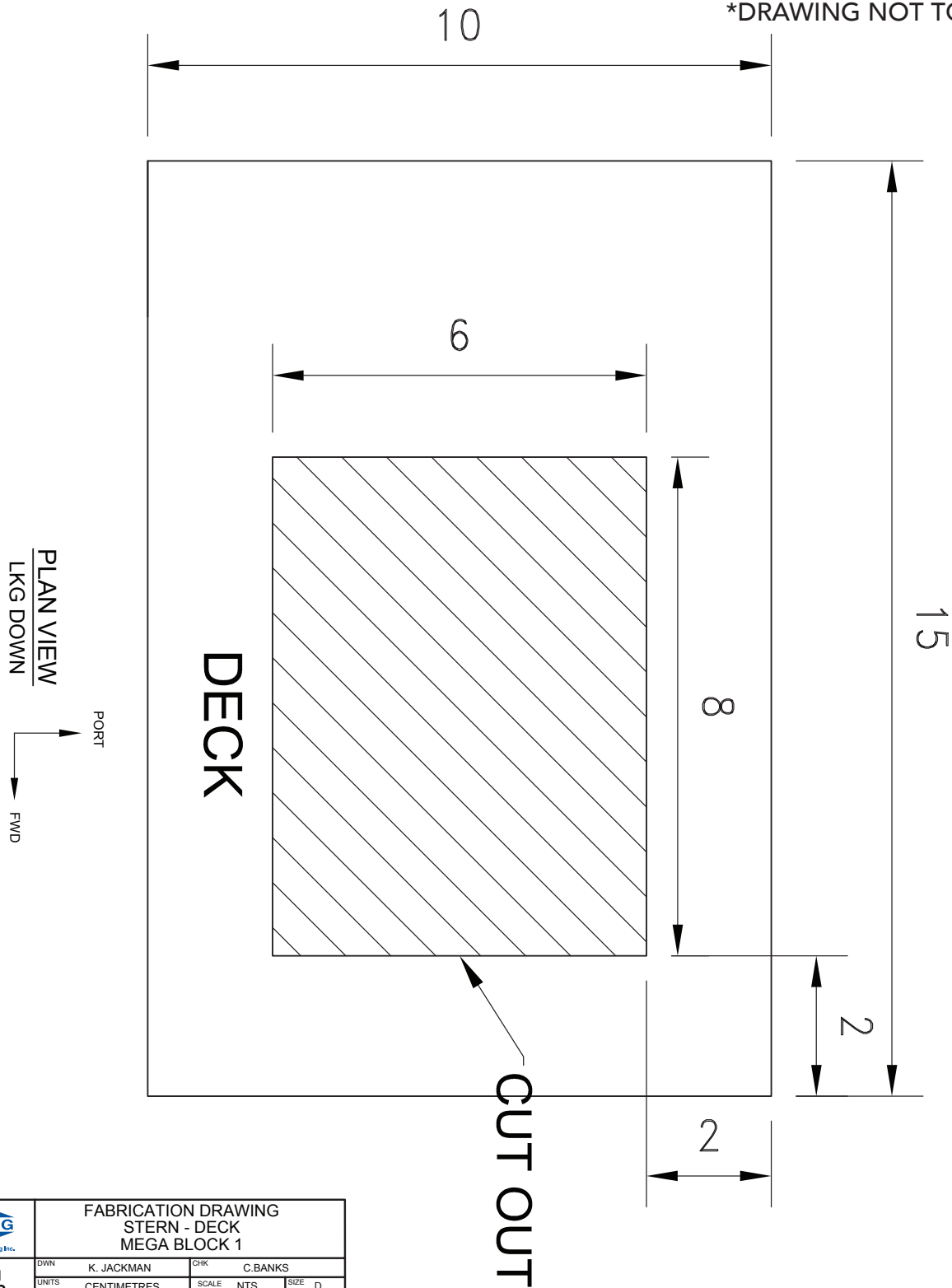

 Irving Shipbuilding Inc.	FABRICATION DRAWING STERN - DECK MEGA BLOCK 1			
	DWN	K. JACKMAN	CHK	C. BANKS
	UNITS	CENTIMETRES	SCALE	NTS
	SHEET	1	DATE	2018-10-29
SHIP 1	DWG NO	A01-STERN PACKAGE-003	REV	A

© IRVING SHIPBUILDING INC. ALL RIGHTS RESERVED

BILL OF MATERIALS		
NAME	QUANTITY	MATERIAL DESCRIPTION
STERN - SHELL	1	21.5X28CM BLACK PLASTIC PAPER

NOTES:

1. ALL DIMENSIONS IN CENTIMETERS
2. FIRST DRAW ALL THE FOLD LINES AS SHOWN IN PLAN VIEW 1, DO NOT FOLD YET
3. CUT ALONG THE LINES SHOWN IN PLAN VIEW 2
4. MARK AN X IN THE CENTER OF THE THREE END SECTIONS
5. FOLD ALONG THE FOLD LINES
6. BRING THE END SECTIONS TOGETHER SO THAT THE X'S ALL OVERLAP, WITH THE MIDDLE SECTION ON THE INSIDE

***DRAWINGS NOT TO SCALE**

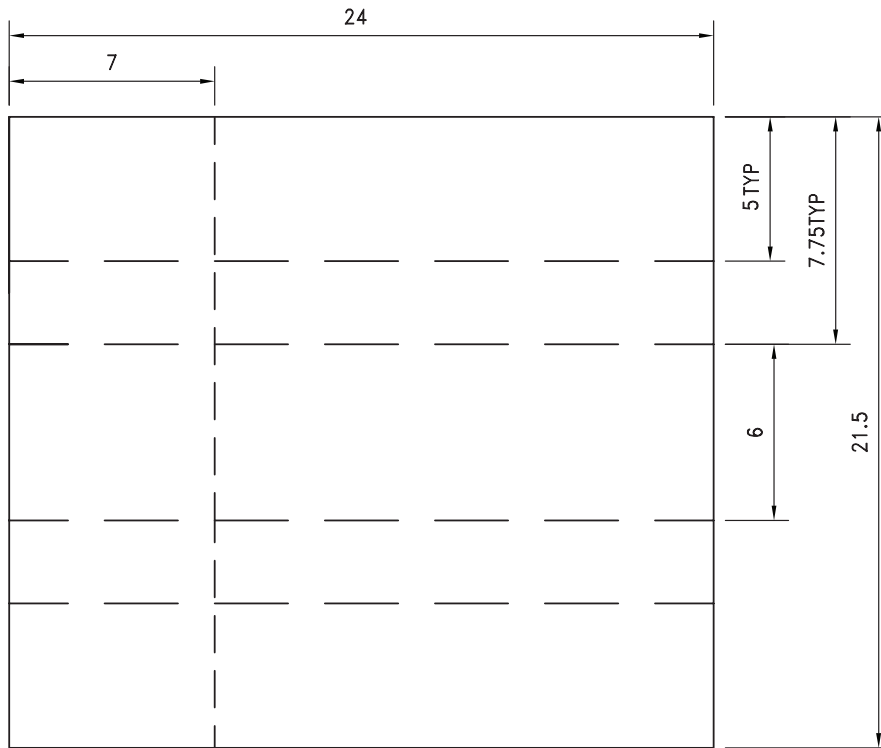

PLAN VIEW 1
LKG DOWN

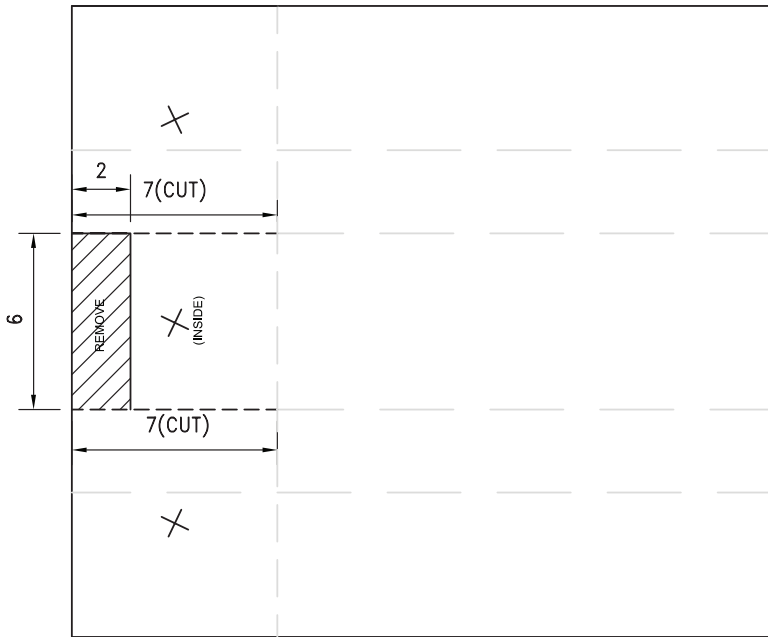
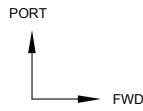

PLAN VIEW 2
LKG DOWN

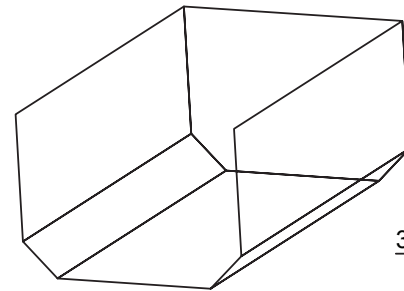

3D VIEW

 Irving Shipbuilding Inc.	FABRICATION DRAWING STERN - SHELL MEGA BLOCK 1			
	DWN	K. JACKMAN	CHK	C. BANKS
	UNITS	CENTIMETRES	SCALE	NTS SIZE D
	SHEET	1	DATE	2018-10-29
SHIP 1	DWG NO. A01-STERN PACKAGE-004		REV. A	

© IRVING SHIPBUILDING INC. ALL RIGHTS RESERVED

PARTS LIST	
NAME	QUANTITY
STERN - SHELL	1
STERN - LONGITUDINAL BULKHEAD	1
STERN- TRANSVERSE BULKHEAD	1
STERN - DECK	1

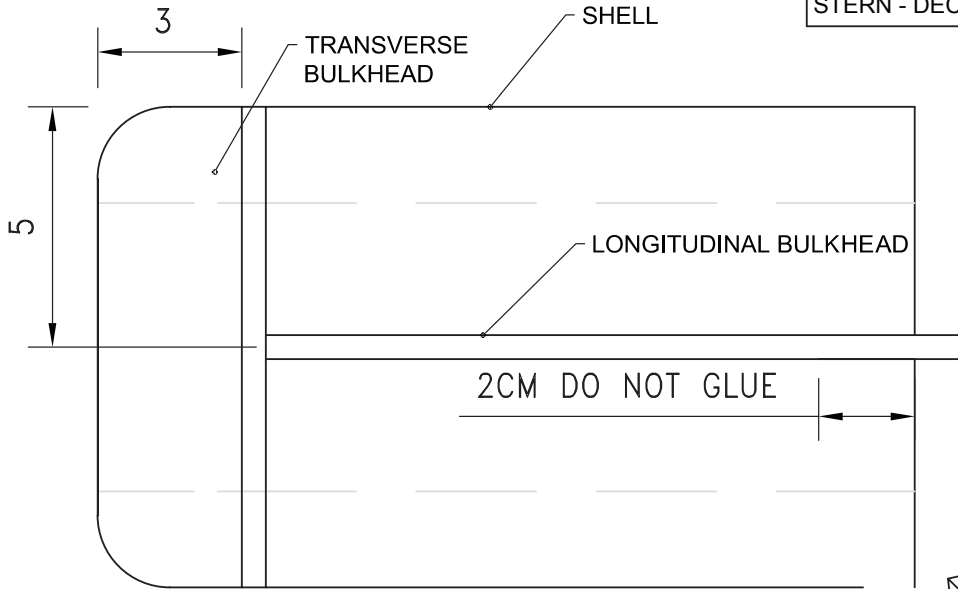

PLAN VIEW 1
LKG DOWN
BULKHEAD INSTALLATION

PORT ↑
FWD →

- NOTES:**
1. ALL DIMENSIONS IN CENTIMETERS
 2. INSTALL TRANSVERSE AND LONGITUDINAL BULKHEADS ONTO THE SHELL AS SHOWN IN PLAN VIEW 1
 3. INSTALL DECK ON TOP AS SHOWN IN PLAN VIEW 2

***DRAWINGS NOT TO SCALE**

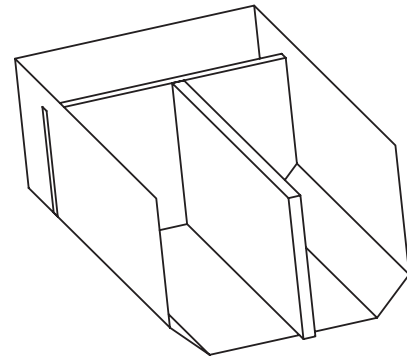

3D VIEW
(DECK NOT SHOWN FOR CLARITY)

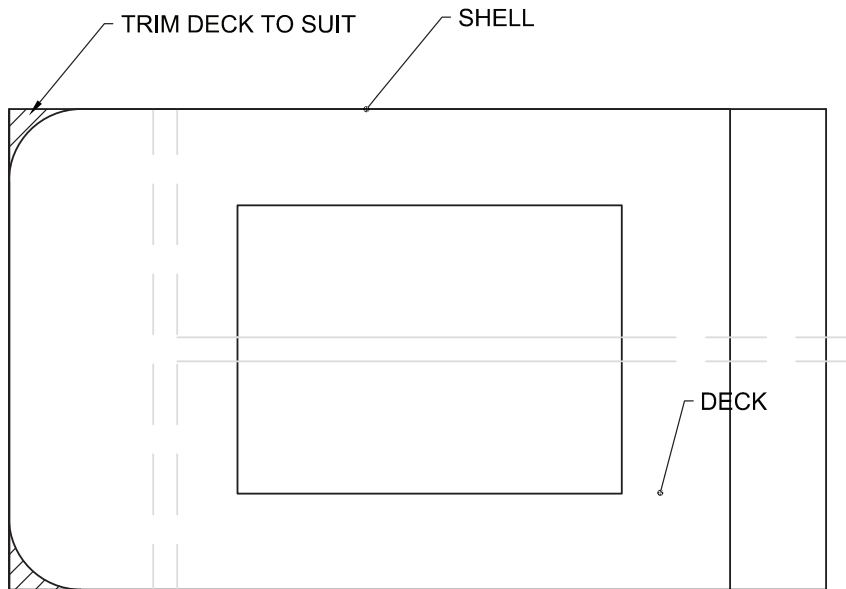

PLAN VIEW 2
LKG DOWN
DECK INSTALLATION

PORT ↑
FWD →

IRVING Irving Shipbuilding Inc.					ASSEMBLY DRAWING STERN ASSEMBLY MEGA BLOCK 1		
STEM CLASS	DWN	K. JACKMAN	CHK	C.BANKS			
	UNITS	MILLIMETERS	SCALE	NTS	SIZE	D	
	SHEET	1	DATE	2018-10-29			
SHIP 1	DWG NO	A01-STERN PACKAGE-005			REV	A	

© IRVING SHIPBUILDING INC. ALL RIGHTS RESERVED

BILL OF MATERIALS		
NAME	QUANTITY	ATERIAL DESCRIPTION
MAST	1	21.5X28CM BLACK PLASTIC PAPER

NOTES:

1. ALL DIMENSIONS IN CENTIMETERS
2. ROLL THE PAPER OVERLAPPING THE BLACK DOTS
3. USE A COMPASS TO DRAW A CIRCLE FOR THE TOP
4. INSTALL FLAG ON TOP

***DRAWINGS NOT TO SCALE**

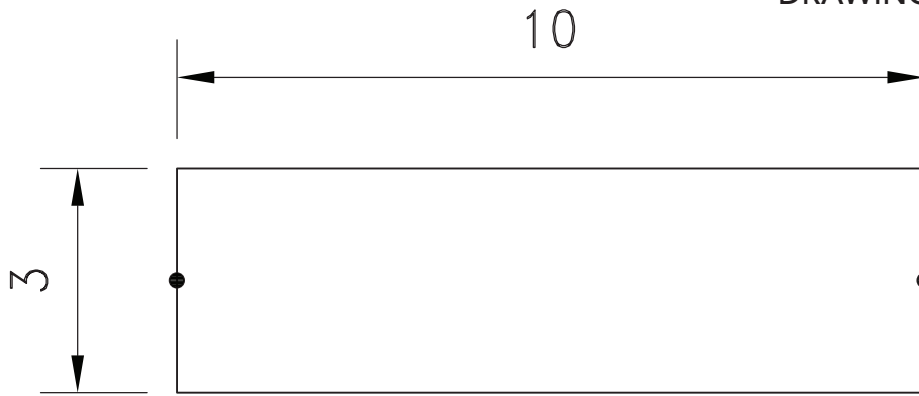

SECTION 1
LKG PORT

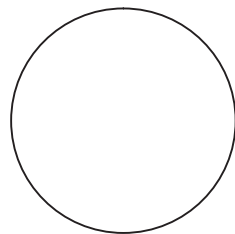
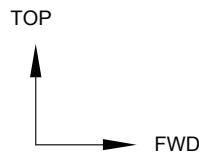

PLAN VIEW
LKG DOWN

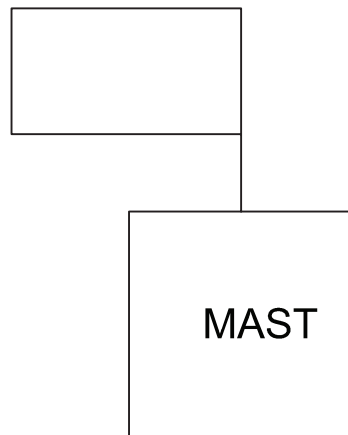
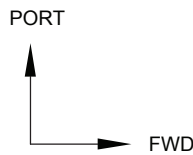

SECTION 2
LKG PORT

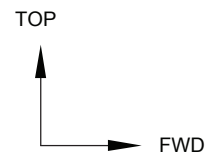

 STEM CLASS SHIP 1	ASSEMBLY DRAWING MAST ASSEMBLY			
	DWN	K. JACKMAN	CHK	C.BANKS
	UNITS	CENTIMETRES	SCALE	NTS SIZE D
	SHEET	1	DATE	2018-10-29
	DWG NO	A01-STERN PACKAGE-006	REV	A

© IRVING SHIPBUILDING INC. ALL RIGHTS RESERVED

Construction of Mega-Block 2

ACTIVITY

To Construct Midship Section of a STEM-class Ship – Mega-Block 2.

NOTES

- Ensure optimal utilization of all materials to reduce waste
- Ensure all cutting surfaces are protected when cutting materials with the use of a cutting board
- Take note of the quantity required within the bill of materials section of the drawing attachments

MATERIAL REQUIREMENTS

- Permanent Marker
- Clear Ruler
- Exacto Knife
- Cutting Board
- Foam Board
- Poly covers or Plastic sheets
- Scissors
- Glue Gun
- Duct Tape

DEFINITIONS

Bulkhead: a dividing wall or barrier between compartments in a ship

Deck: a structure approximately horizontal, extending across a ship

Longitudinal: situated along the length of the ship

Port: the left side of the ship

Shell: the outer most structure of a ship

Starboard: the right side of the ship

Stern: the back most part of the ship

Transverse: situated across the width of the ship

Superstructure: the part of the ship that rises above the hull

ACRONYMS

DWG: Drawing

FWD: Forward

LKG FWD: Looking Forward

LKG DWN: Looking Down

LKG PORT: Looking Port

PS: Port Side

STBD: Starboard

TYP: Typical, meaning the same on both sides

Construction of Mega-Block 2

STEPS

1.0 Midship-Transverse Bulkhead

- 1.1 Using Midship-Transverse Bulkhead drawing (p.18) measure, mark-up and cut out section of foam board using an exacto knife to the exact measurements stipulated on the drawing.
- 1.2 Repeat step 1.1 to create a second Transverse Bulkhead section.

2.0 Midship-Longitudinal Bulkhead

- 2.1 Using Midship-Longitudinal Bulkhead drawing (p.19) measure, mark-up and cut out section of foam board using an exacto knife to the exact measurements stipulated on the drawing.

3.0 Midship-Deck

- 3.1 Using Midship-Deck drawing (p.20) measure, mark-up and cut out section of foam board using an exacto knife to the exact measurements stipulated on the drawing.

4.0 Midship-Shell

- 4.1 Using Midship-Shell drawing (p.21) measure, mark-up and cut out section of poly covers or plastic sheets using scissors, to the exact measurements stipulated on the drawing.
- 4.2 Measure, mark-up and fold section of poly covers or plastic sheets to exact measurements stipulated on the drawing to form the shape indicated.

5.0 Midship-Assembly

- 5.1 Using Midship-Assembly drawing (p.22) follow the 'NOTES' section to assemble Transverse Bulkhead, Longitudinal Bulkhead, Deck & Shell to form Mega-Block 2.
- 5.2 Use glue gun to secure sections.

6.0 Superstructure-Assembly

- 6.1 Using Superstructure-Assembly drawing (p.23) measure, mark-up and cut poly covers or plastic sheets using scissors to the exact measurements stipulated on the drawing.
- 6.2 Follow the 'NOTES' section to form the structure indicated on the drawing.
- 6.3 Use glue gun to secure.

BILL OF MATERIALS		
NAME	QUANTITY	MATERIAL DESCRIPTION
MIDSHIP - TRANSVERSE BULKHEAD	2	0.5CM THICK FOAM BOARD

NOTES:
 1. ALL DIMENSIONS IN CENTIMETERS
 *DRAWING NOT TO SCALE

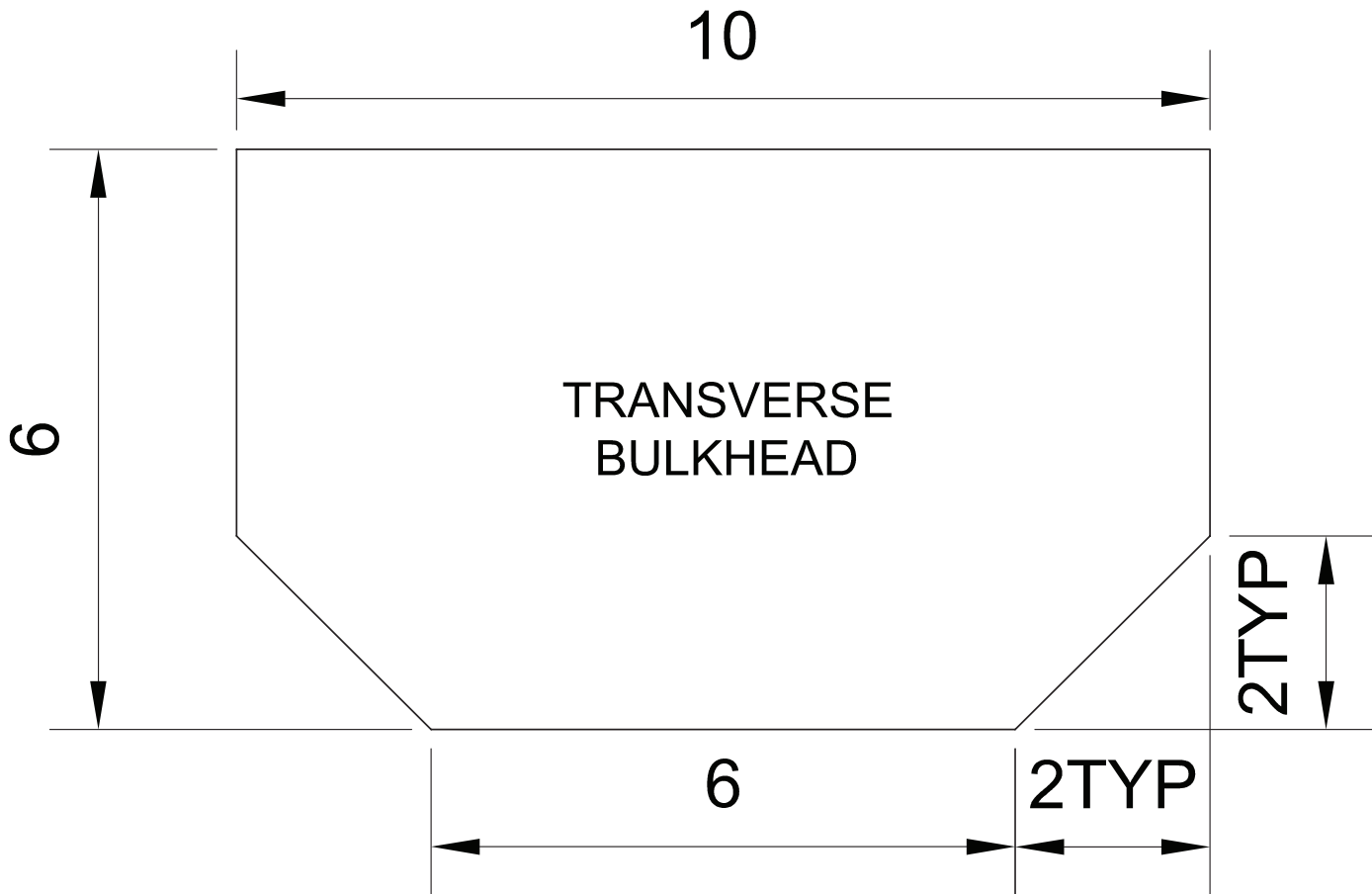

SECTION
LKG FWD

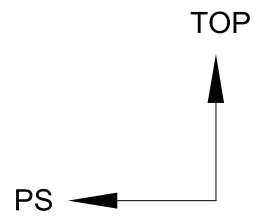



 IRVING Shipbuilding Inc. STEM CLASS SHIP 1	FABRICATION DRAWING MIDSHIP - TRANSVERSE BULKHEAD MEGA BLOCK 2			
	DWN	K. JACKMAN	CHK	C. BANKS
	UNITS	CENTIMETRES	SCALE	NTS
	SHEET	1	DATE	2018-10-29
DWG NO	A01-MIDSHIP PACKAGE-001	REV	A	

© IRVING SHIPBUILDING INC. ALL RIGHTS RESERVED

BILL OF MATERIALS		
NAME	QUANTITY	MATERIAL DESCRIPTION
MIDSHIP - LONGITUDINAL BULKHEAD	1	0.5CM THICK FOAM BOARD

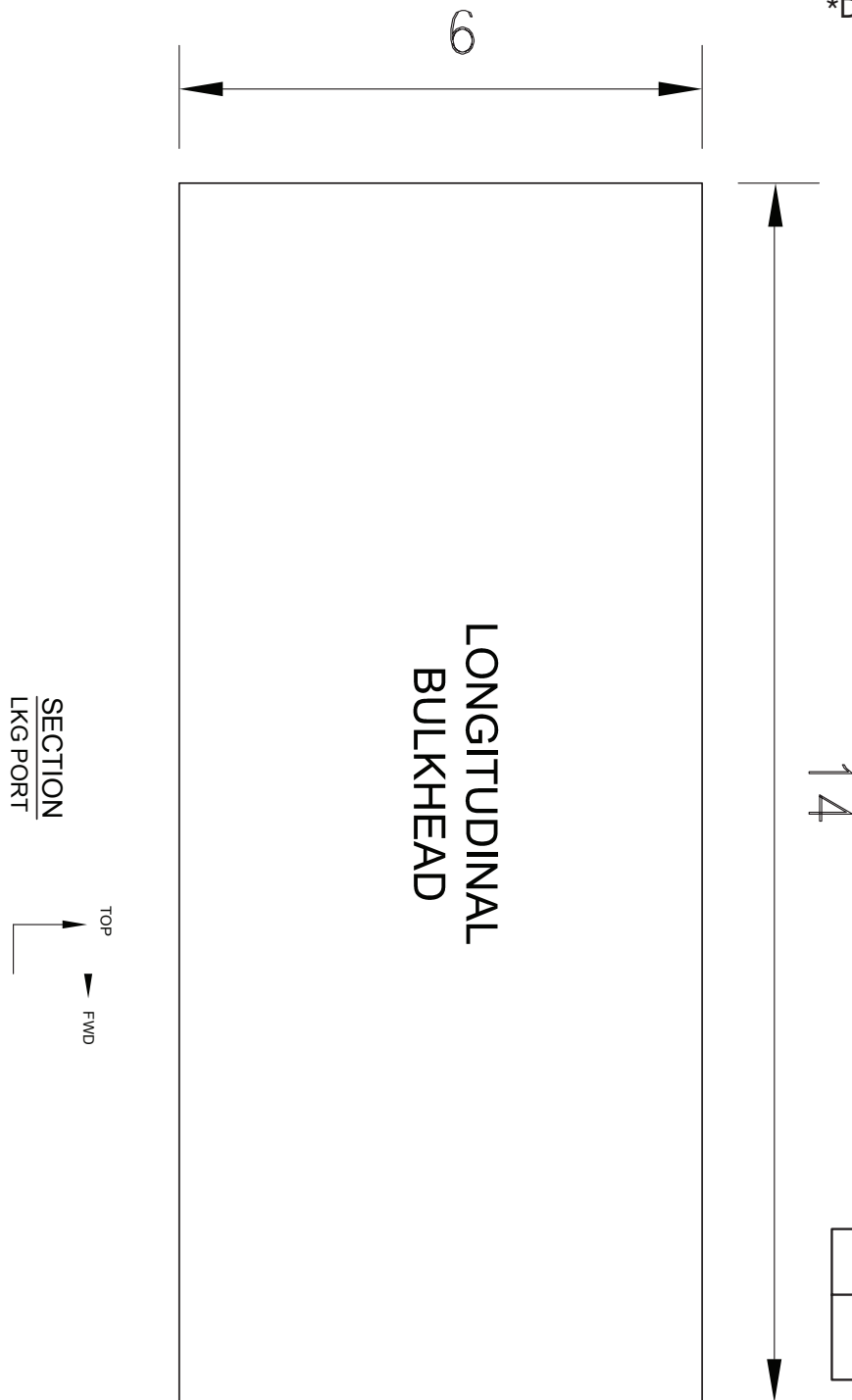
NOTES:
 1. ALL DIMENSIONS IN CENTIMETERS
 *DRAWING NOT TO SCALE



 Irving Shipbuilding Inc.	FABRICATION DRAWING			
	MIDSHIP-LONGITUDINAL BULKHEAD			
	MEGA BLOCK 2			
	DWN	K. JACKMAN	CHK	C. BANKS
	UNITS	CENTIMETRES	SCALE	NTS SIZE D
SHEET	1	DATE	2018-10-29	
DWG NO	A01-MIDSHIP PACKAGE-002		REV A	

© IRVING SHIPBUILDING INC. ALL RIGHTS RESERVED

BILL OF MATERIALS		
NAME	QUANTITY	MATERIAL DESCRIPTION
MIDSHIP - DECK	1	0.5CM THICK FOAM BOARD

NOTES:
 1. ALL DIMENSIONS IN CENTIMETERS
 *DRAWING NOT TO SCALE

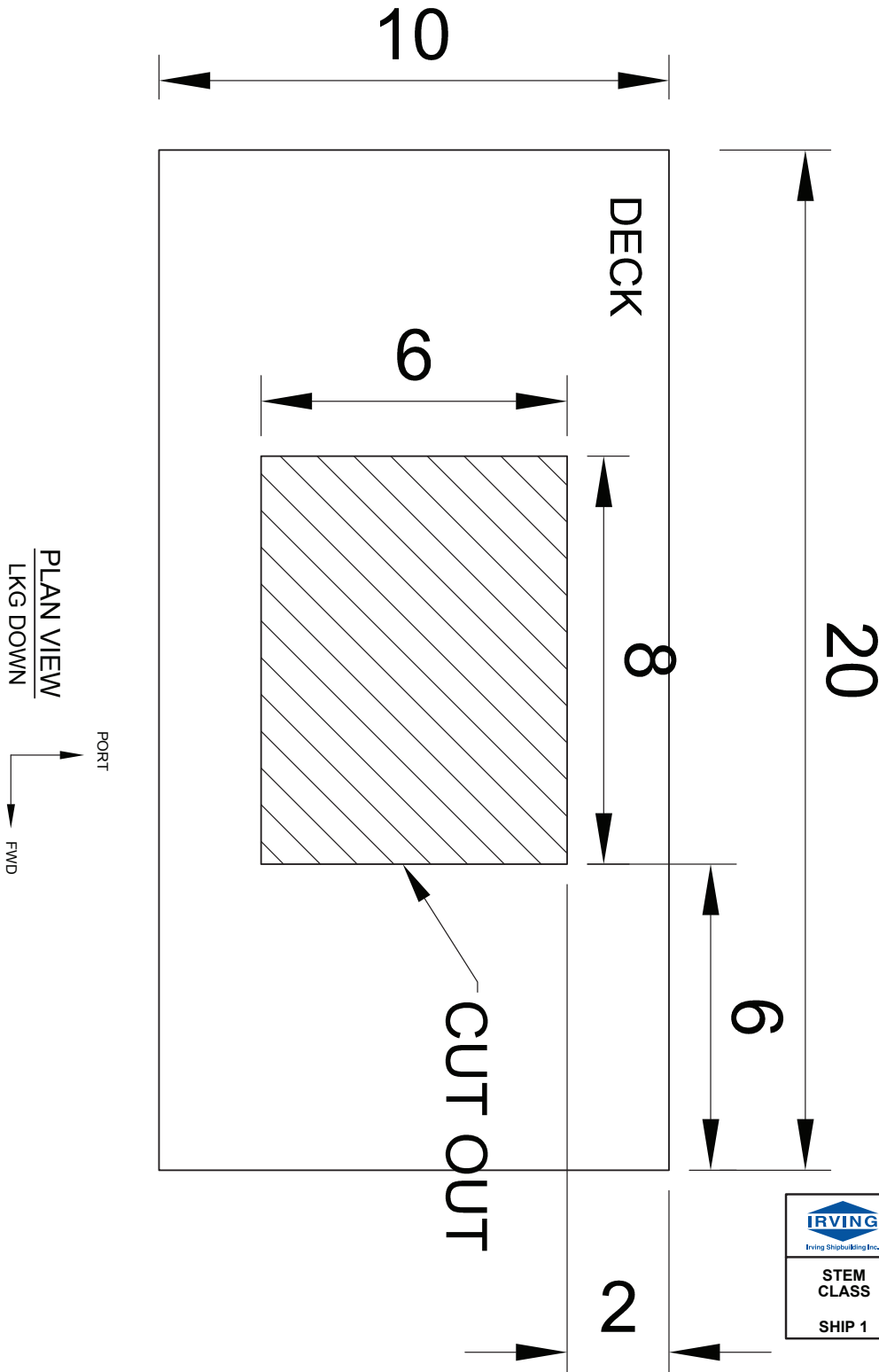

 STEM CLASS SHIP 1	DWN	K. JACKMAN	CHK	C. BANKS
	UNITS	CENTIMETRES	SCALE	NTS
	SHEET	1	DATE	2018-10-29
	DWG NO	A01-MIDSHIP PACKAGE-003		REV

© IRVING SHIPBUILDING INC. ALL RIGHTS RESERVED

BILL OF MATERIALS		
NAME	QUANTITY	MATERIAL DESCRIPTION
MIDSHIP - SHELL1		21.5X28CM BLACK PLASTIC PAPER

NOTES:
 1.ALL DIMENSIONS IN CENTIMETERS
 2.DRAW AND FOLD ALONG FOLD LINES
 *DRAWING NOT TO SCALE

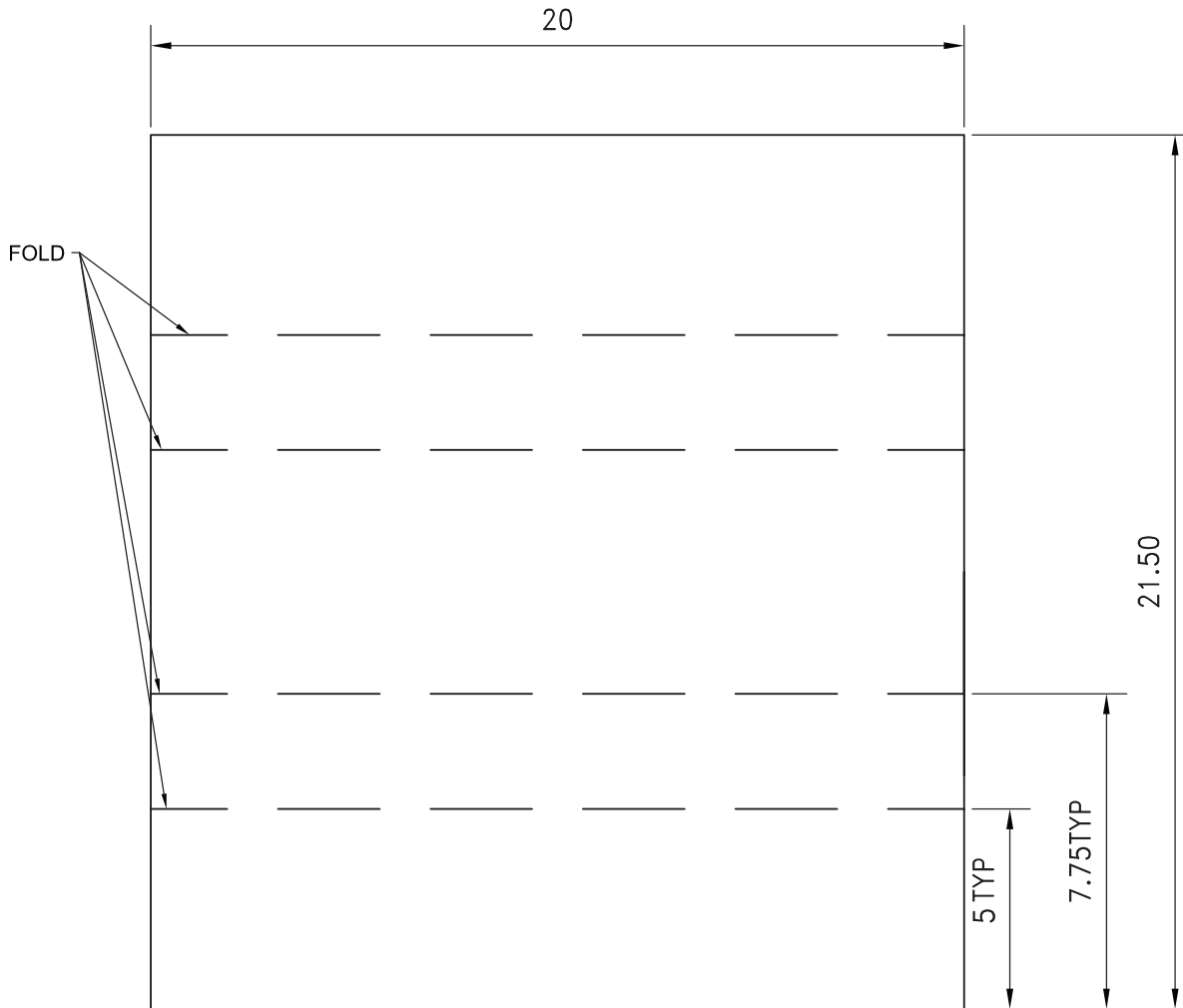

PLAN VIEW 2
 LKG DOWN

PORT ↑
 FWD →

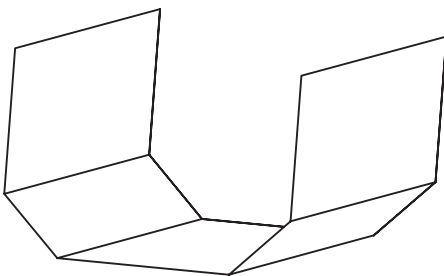

3D VIEW

IRVING Irving Shipbuilding Inc.				
FABRICATION DRAWING MIDSHIP-SHELL MEGA BLOCK 2				
DWN	K. JACKMAN	CHK	C.BANKS	
UNITS	CENTIMETRES	SCALE	NTS	SIZE D
SHEET	1	DATE	2018-10-29	
SHIP 1	DWG NO	A01-MIDSHIP PACKAGE-004	REV	A

© IRVING SHIPBUILDING INC. ALL RIGHTS RESERVED

PARTS LIST	
NAME	QUANTITY
MIDSHIP - SHELL1	
MIDSHIP - LONGITUDINAL BULKHEAD	1
MIDSHIP - TRANSVERSE BULKHEAD	2
MIDSHIP - DECK	1

NOTES:
 1. ALL DIMENSIONS IN CENTIMETERS
 2. INSTALL TRANSVERSE AND LONGITUDINAL BULKHEADS ONTO THE SHELL AS SHOWN IN PLAN VIEW 1
 3. INSTALL DECK ON TOP AS SHOWN IN PLAN VIEW 2
 *DRAWING NOT TO SCALE

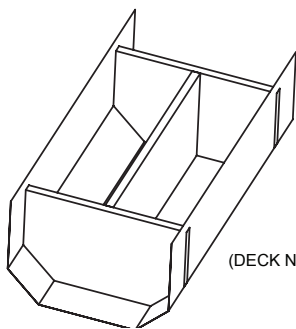
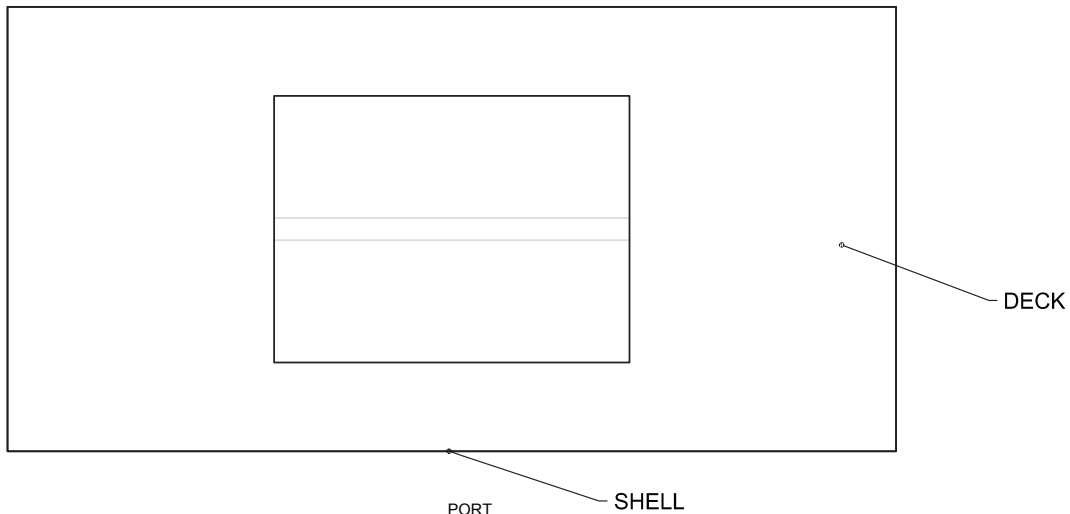
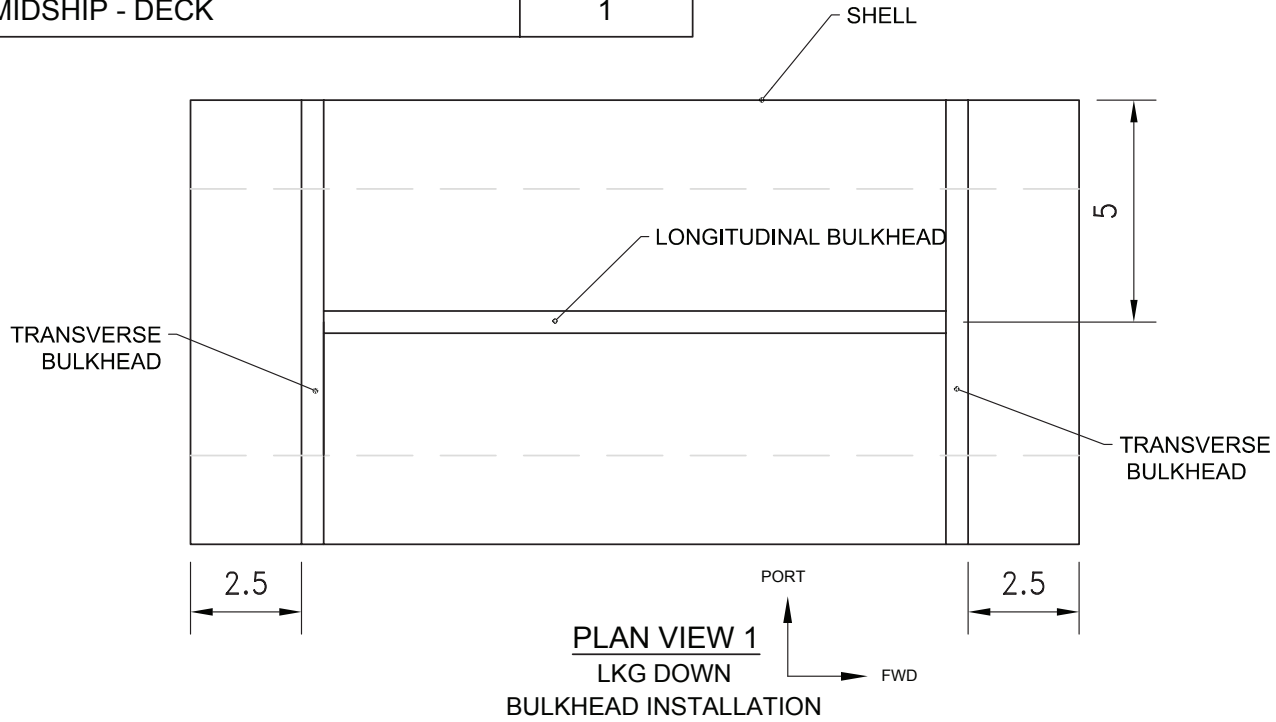

3D VIEW
(DECK NOT SHOWN FOR CLARITY)

PLAN VIEW 2
LKG DOWN

IRVING Irving Shipbuilding Inc.				ASSEMBLY DRAWING MIDSHIP ASSEMBLY MEGA BLOCK 2			
STEM CLASS	DWN	K. JACKMAN	CHK	C. BANKS			
	UNITS	CENTIMETRES		SCALE	NTS	SIZE	D
	SHEET	1		DATE	2018-10-29		
SHIP 1	DWG NO	A01-MIDSHIP PACKAGE-005			REV	A	

© IRVING SHIPBUILDING INC. ALL RIGHTS RESERVED

BILL OF MATERIALS

NAME	QUANTITY	MATERIAL DESCRIPTION
SUPERSTRUCTURE	1	21.5X28CM BLACK PLASTIC PAPER

NOTES:

1. ALL DIMENSIONS IN CENTIMETERS
2. FOLD ALONG FOLD LINES, AND CUT SECTIONS AS SHOWN
3. ONCE FOLDING AND CUTTING IS COMPLETE, BRING THE ORANGE CIRCLES TOGETHER WITH THE MIDDLE SECTION INSIDE
3. BRING THE BLUE CIRCLES TOGETHER, WITH THE INNER TRIANGLES ON THE INSIDE AS INDICATED. DO THE SAME WITH THE OTHER SIDE (PINK CIRCLES)

*DRAWING NOT TO SCALE

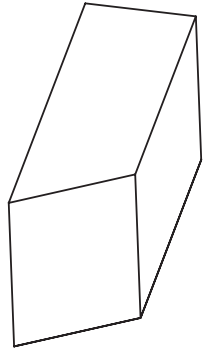

3D VIEW

IRVING		ASSEMBLY DRAWING	
PAPER SUPPLY SERVICES INC.		SUPERSTRUCTURE ASSEMBLY	
DRAWN	K. JACKMAN	CHKD	C. BANKS
STEM CLASS		UNITS	CENTIMETRES
SCALE	NTS	SIZE	D
SHEET	1	DATE	2018-10-29
DWG NO	A01-MIDSHIP PACKAGE-006	REV	A

© IRVING SHIPBUILDING INC. ALL RIGHTS RESERVED

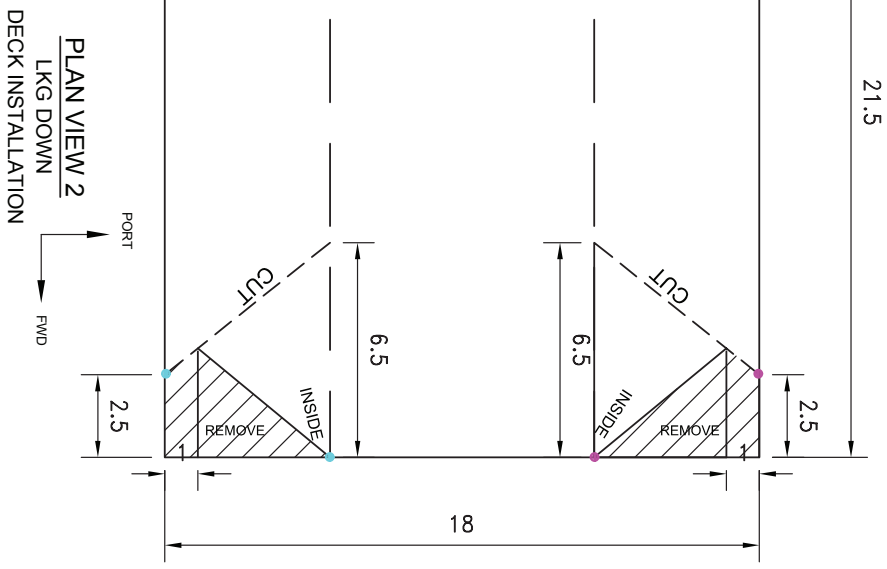
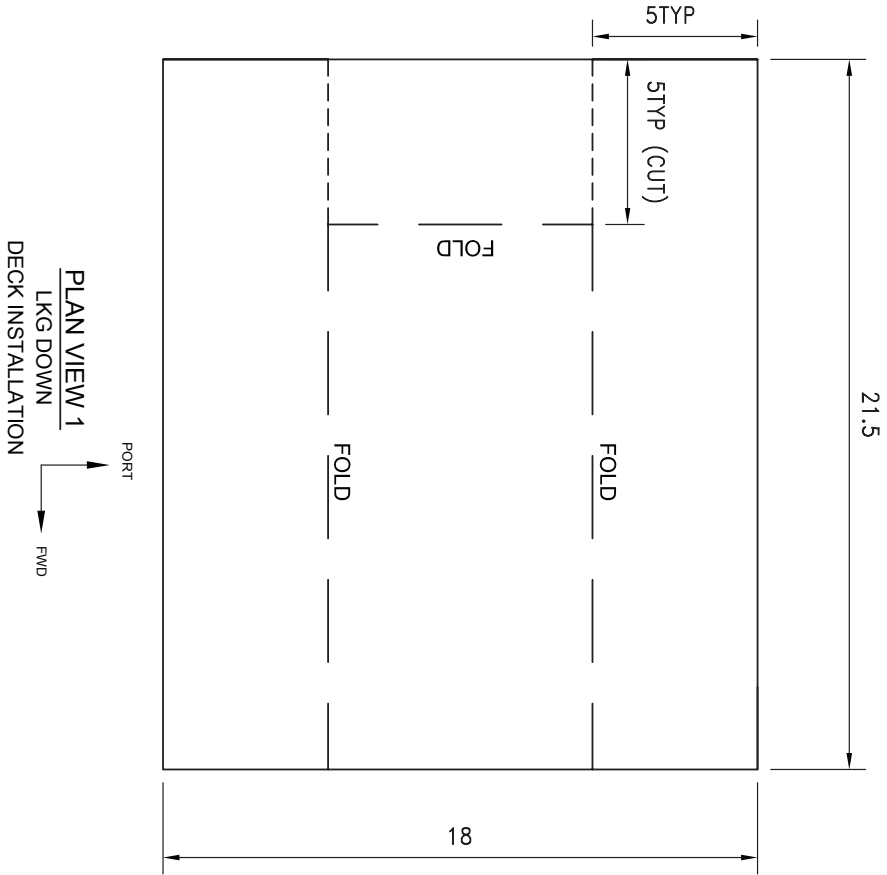

Construction of Mega-Block 3

ACTIVITY

To Construct Bow Section of a STEM-class Ship – Mega-Block 3.

NOTES

- Ensure optimal utilization of all materials to reduce waste
- Ensure all cutting surfaces are protected when cutting materials with the use of a cutting board

MATERIAL REQUIREMENTS

- Permanent Marker
- Clear Ruler
- Exacto Knife
- Cutting Board
- Foam Board
- Poly covers or Plastic sheets
- Scissors
- Glue Gun
- Duct Tape
- Canada Flag

DEFINITIONS

Bulkhead: a dividing wall or barrier between compartments in a ship

Deck: a structure approximately horizontal, extending across a ship

Longitudinal: situated along the length of the ship

Port: the left side of the ship

Shell: the outer most structure of a ship

Starboard: the right side of the ship

Stern: the back most part of the ship

Transverse: situated across the width of the ship

Superstructure: the part of the ship that rises above the hull

ACRONYMS

DWG: Drawing

FWD: Forward

LKG FWD: Looking Forward

LKG DWN: Looking Down

LKG PORT: Looking Port

PS: Port Side

STBD: Starboard

TYP: Typical, meaning the same on both sides

Construction of Mega-Block 3

STEPS

1.0 Bow-Transverse Bulkhead

1.1 Using Bow-Transverse Bulkhead drawing (p.26) measure, mark-up and cut out section of foam board using an exacto knife to the exact measurements stipulated on the drawing.

2.0 Bow-Longitudinal Bulkhead

2.1 Using Bow-Longitudinal Bulkhead drawing (p.27) measure, mark-up and cut out section of foam board using an exacto knife to the exact measurements stipulated on the drawing.

3.0 Bow-Deck

3.1 Using Bow-Deck drawing (p.28) measure, mark-up and cut out section of foam board using an exacto knife to the exact measurements stipulated on the drawing.

4.0 Bow-Shell

4.1 Using Bow-Shell drawing (p.29) follow the 'NOTES' section to mark-up, fold and cut poly covers or plastic sheets using scissors to the exact measurements stipulated on the drawing.

4.2 Use glue gun to secure sections.

5.0 Bow-Assembly

5.1 Using Bow-Assembly drawing (p.30) assemble Transverse Bulkhead, Longitudinal Bulkhead, Deck & Shell to form Mega-Block 3.

5.2 Use glue gun to secure sections.

BILL OF MATERIALS		
NAME	QUANTITY	MATERIAL DESCRIPTION
BOW - TRANSVERSE BULKHEAD	1	0.5CM THICK FOAM BOARD

NOTES:
1. ALL DIMENSIONS IN CENTIMETERS
*DRAWING NOT TO SCALE

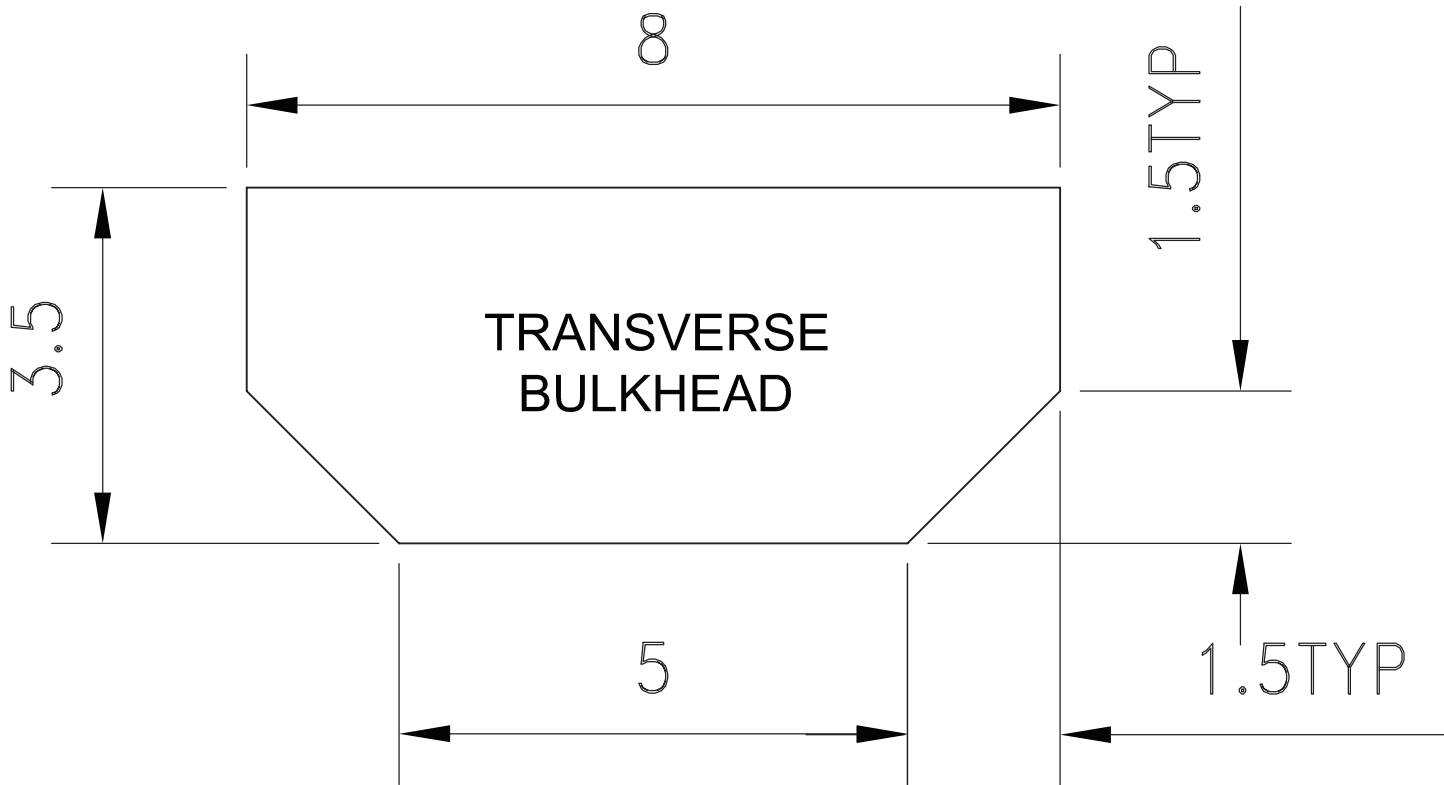

SECTION
LKG FWD

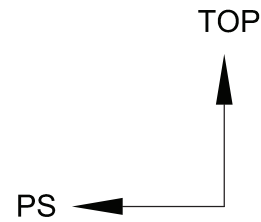

 STEM CLASS SHIP 1	FABRICATION DRAWING BOW - TRANSVERSE BULKHEAD MEGA BLOCK 3			
	DWN	K. JACKMAN	CHK	C.BANKS
	UNITS	CENTIMETRES	SCALE	NTS SIZE D
	SHEET	1	DATE	2018-10-29
	DWG NO	A01-BOW PACKAGE-001	REV	A

© IRVING SHIPBUILDING INC. ALL RIGHTS RESERVED

BILL OF MATERIALS		
NAME	QUANTITY	MATERIAL DESCRIPTION
BOW - LONGITUDINAL BULKHEAD	1	0.5CM THICK FOAM BOARD

NOTES:
 1. ALL DIMENSIONS IN CENTIMETERS
 *DRAWING NOT TO SCALE

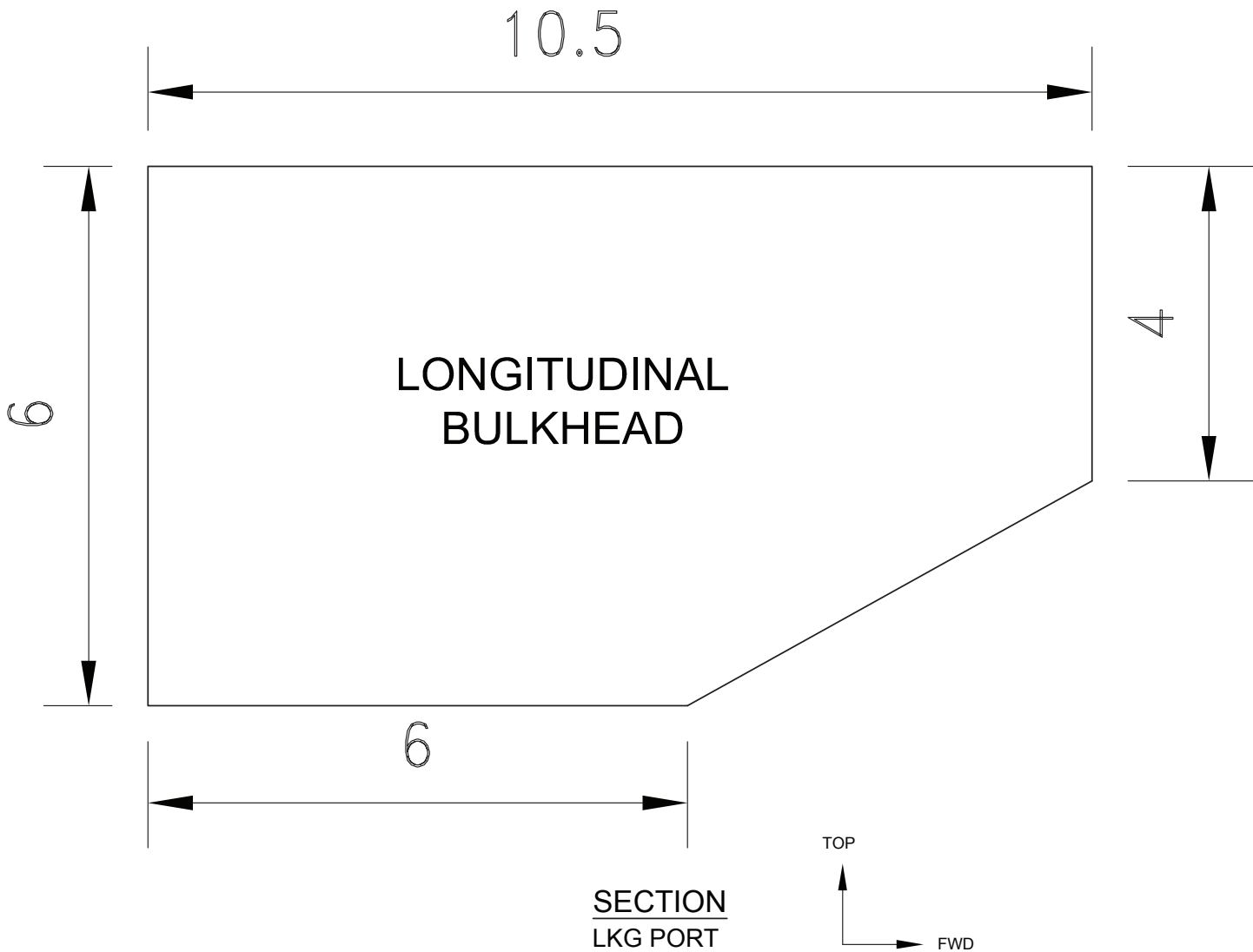

 <small>Irving Shipbuilding Inc.</small>	FABRICATION DRAWING			
	BOW - LONGITUDINAL BULKHEAD			
	MEGA BLOCK 3			
	DWN	K. JACKMAN	CHK	C. BANKS
STEM CLASS	UNITS	SCALE	SIZE	
	CENTIMETRES	NTS	D	
	SHEET	DATE		
	1	2018-10-29		
SHIP 1	DWG NO	REV		
	A01-BOW PACKAGE-002	A		

© IRVING SHIPBUILDING INC. ALL RIGHTS RESERVED

BILL OF MATERIALS		
NAME	QUANTITY	MATERIAL DESCRIPTION
BOW - DECK	1	0.5CM THICK FOAM BOARD

NOTES:
 1. ALL DIMENSIONS IN CENTIMETERS
 *DRAWING NOT TO SCALE

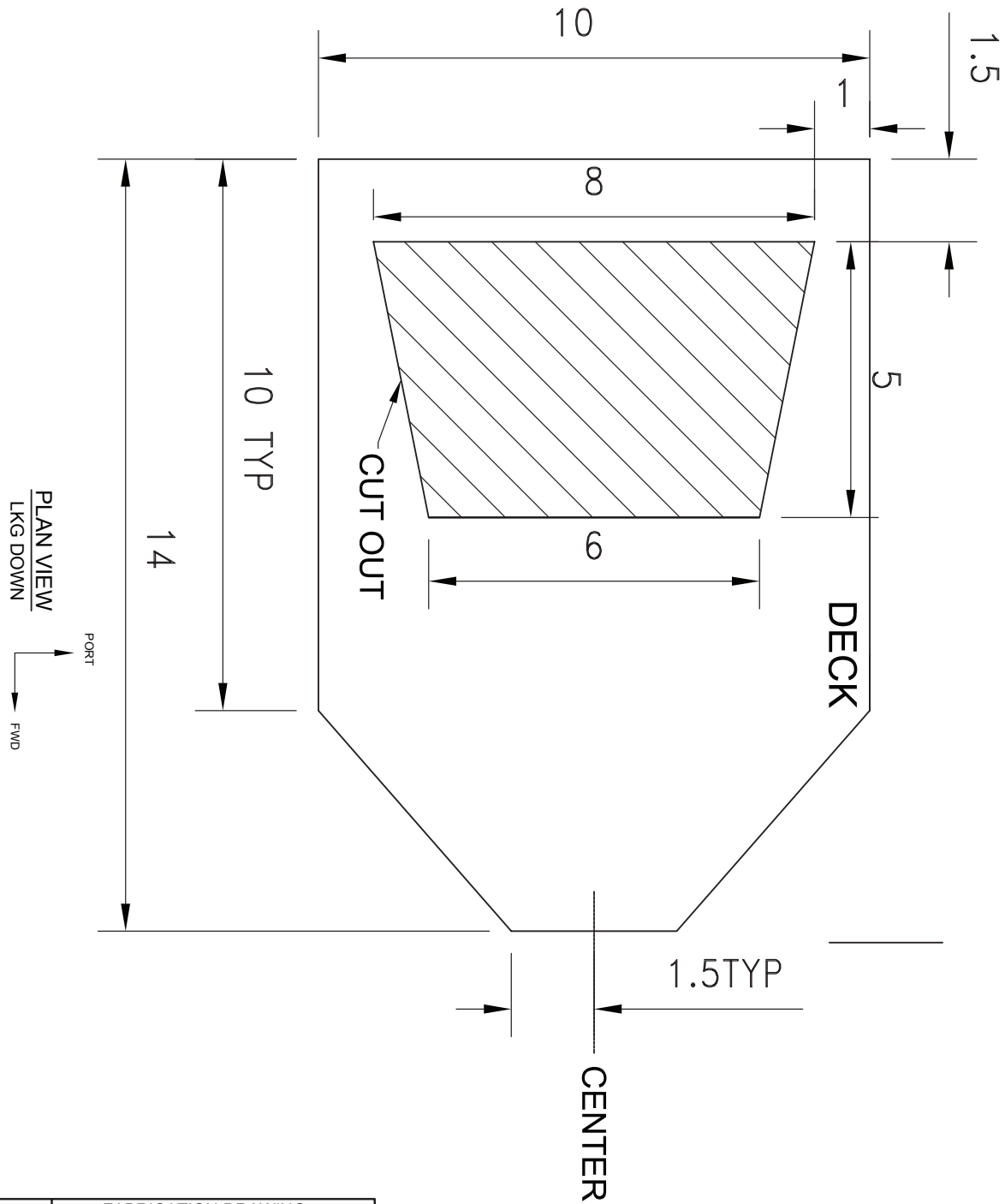



 IRVING Shipbuilding Inc.	FABRICATION DRAWING					
	BOW - DECK					
	MEGA BLOCK 3					
	DWN	K. JACKMAN	CHK	C. BANKS		
STEM CLASS	UNITS	CENTIMETRES	SCALE	NTS	SIZE	D
SHIP 1	SHEET	1	DATE	2018-10-29	REV	A
DWG NO		A01-BOW PACKAGE-003				

© IRVING SHIPBUILDING INC. ALL RIGHTS RESERVED

BILL OF MATERIALS		
NAME	QUANTITY	MATERIAL DESCRIPTION
BOW - SHELL	1	21.5X28CM BLACK PLASTIC PAPER

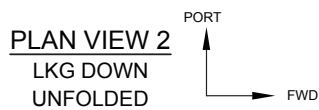
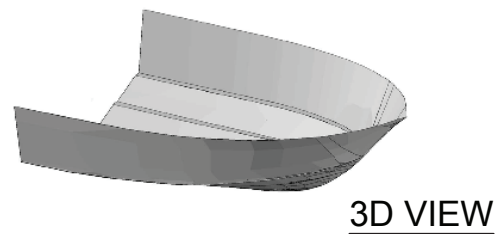
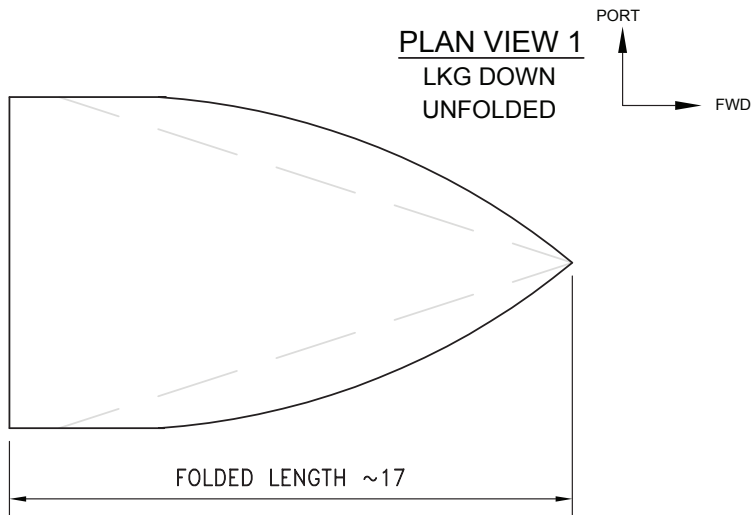
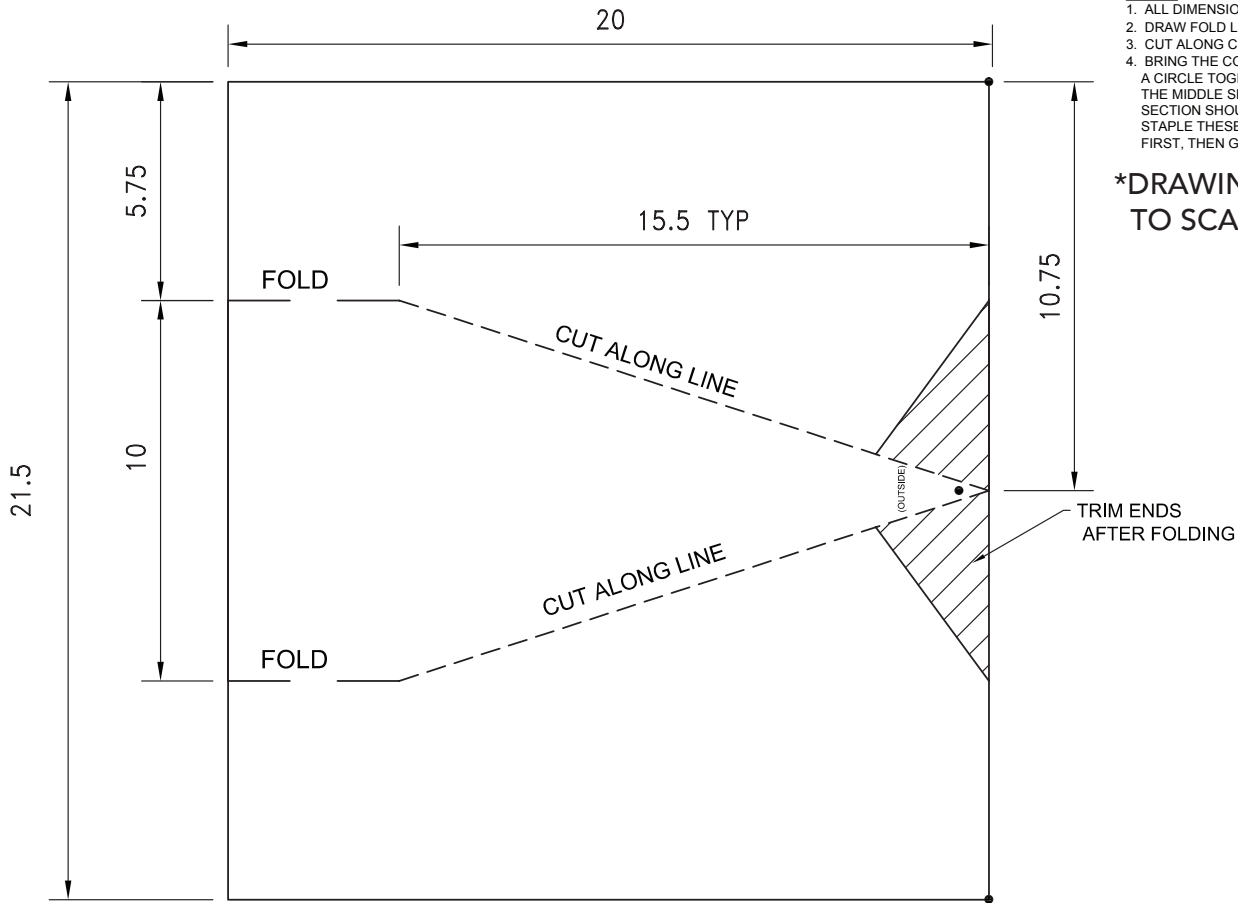
- NOTES:
 1. ALL DIMENSIONS IN CENTIMETERS
 2. DRAW FOLD LINES AND CUT LINES
 3. CUT ALONG CUT LINE
 4. BRING THE CORNERS MARKED WITH A CIRCLE TOGETHER TO OVERLAP. WITH THE MIDDLE SECTION, THE MIDDLE SECTION SHOULD BE ON THE OUTSIDE STAPLE THESE 3 POINTS TOGETHER FIRST, THEN GLUE



FWD				
 Irving Shipbuilding Inc.	FABRICATION DRAWING BOW - SHELL MEGA BLOCK 3			
	DWN	K. JACKMAN	CHK	C. BANKS
STEM CLASS	UNITS	CENTIMETRES	SCALE	NTS
	SHEET	1	DATE	2018-10-29
SHIP 1	DWG NO	A01-BOW PACKAGE-004	REV	A

© IRVING SHIPBUILDING INC. ALL RIGHTS RESERVED

PARTS LIST	
NAME	QUANTITY
BOW - SHELL	1
BOW - LONGITUDINAL BULKHEAD	1
BOW - TRANSVERSE BULKHEAD	1
BOW - DECK	1

NOTES:

1. ALL DIMENSIONS IN CENTIMETERS
2. TRIM BOTTOM PART OF BULKHEADS TO SUIT CURVATURE OF THE SHELL IF NEEDED
3. TRIM THE DECK TO SUIT THE CURVATURE OF THE SHELL

***DRAWING NOT TO SCALE**

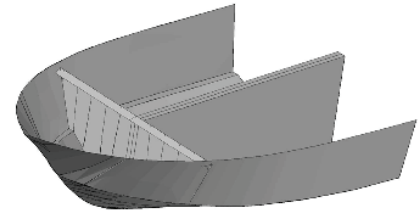
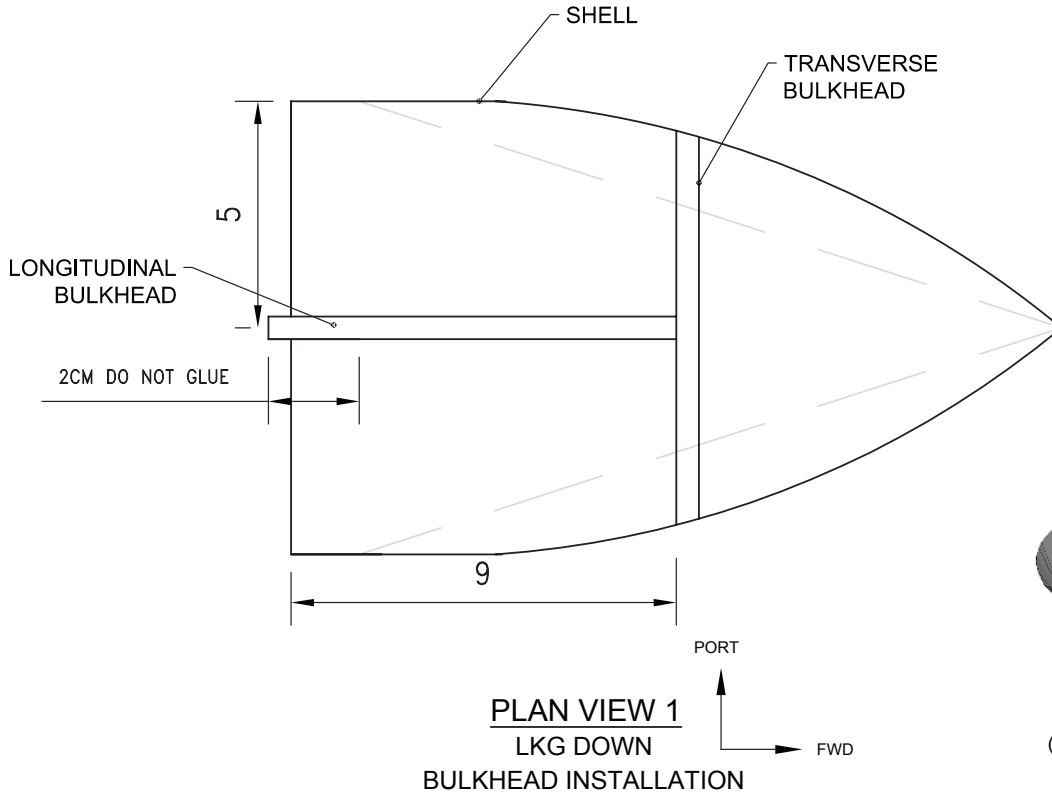

3D VIEW
(DECK NOT SHOWN FOR CLARITY)

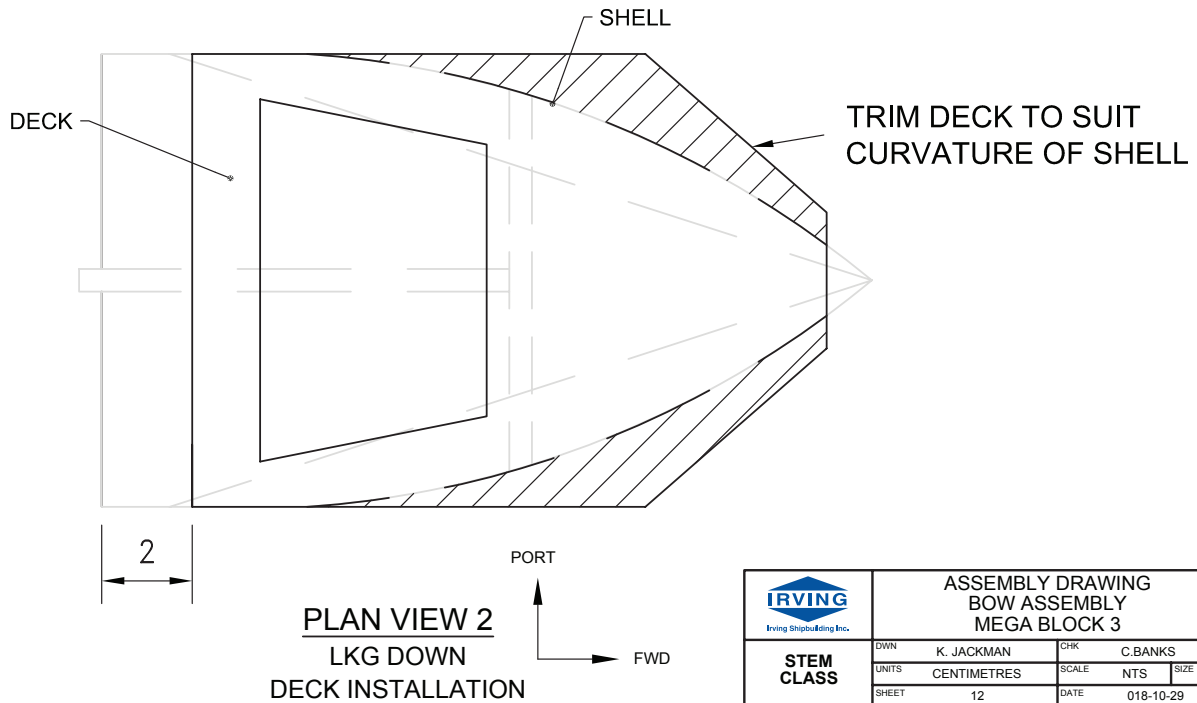

 STEM CLASS SHIP 1	DWN	K. JACKMAN	CHK	C. BANKS
	UNITS	CENTIMETRES	SCALE	NTS SIZE D
	SHEET	12	DATE	018-10-29
	DWG NO	A01-BOW PACKAGE-005	REV	A

© IRVING SHIPBUILDING INC. ALL RIGHTS RESERVED

Final Assembly

ACTIVITY

Final assembly of all three mega-blocks to form the STEM-class ship for the Royal Canadian Navy.

NOTES

- Ensure optimal utilization of all materials to reduce waste
- Ensure all cutting surfaces are protected when cutting materials with the use of a cutting board

MATERIAL REQUIREMENTS

- Permanent Marker
- Clear Ruler
- Exacto Knife
- Cutting Board
- Foam Board
- Poly covers or Plastic sheets
- Scissors
- Glue Gun
- Duct Tape
- Canada Flag
- Weight Source (ex. sand balloons, washers)

STEPS

1.0 Assembly

- 1.1 Using the Mega-Block Join drawing (p.32) follow the 'NOTES' section to assemble STEM-class Ship 1.
- 1.2 Use glue gun to secure sections.
- 1.3 Use duct tape to seal edges.

FINAL ASSESSMENT

Once the vessel is assembled, place it in water to ensure it floats. Leave it in the water and add weight (sand bags, washers, etc.) to each side and section to test the balance of the ship and confirm it is water-tight.

DEFINITIONS

Bulkhead: a dividing wall or barrier between compartments in a ship

Deck: a structure approximately horizontal, extending across a ship

Longitudinal: situated along the length of the ship

Port: the left side of the ship

Shell: the outer most structure of a ship

Starboard: the right side of the ship

Stern: the back most part of the ship

Transverse: situated across the width of the ship

Superstructure: the part of the ship that rises above the hull

ACRONYMS

DWG: Drawing

FWD: Foward

LKG FWD: Looking Forward

LKG DWN: Looking Down

LKG PORT: Looking Port

PS: Port Side

STBD: Starboard

TYP: Typical, meaning the same on both sides

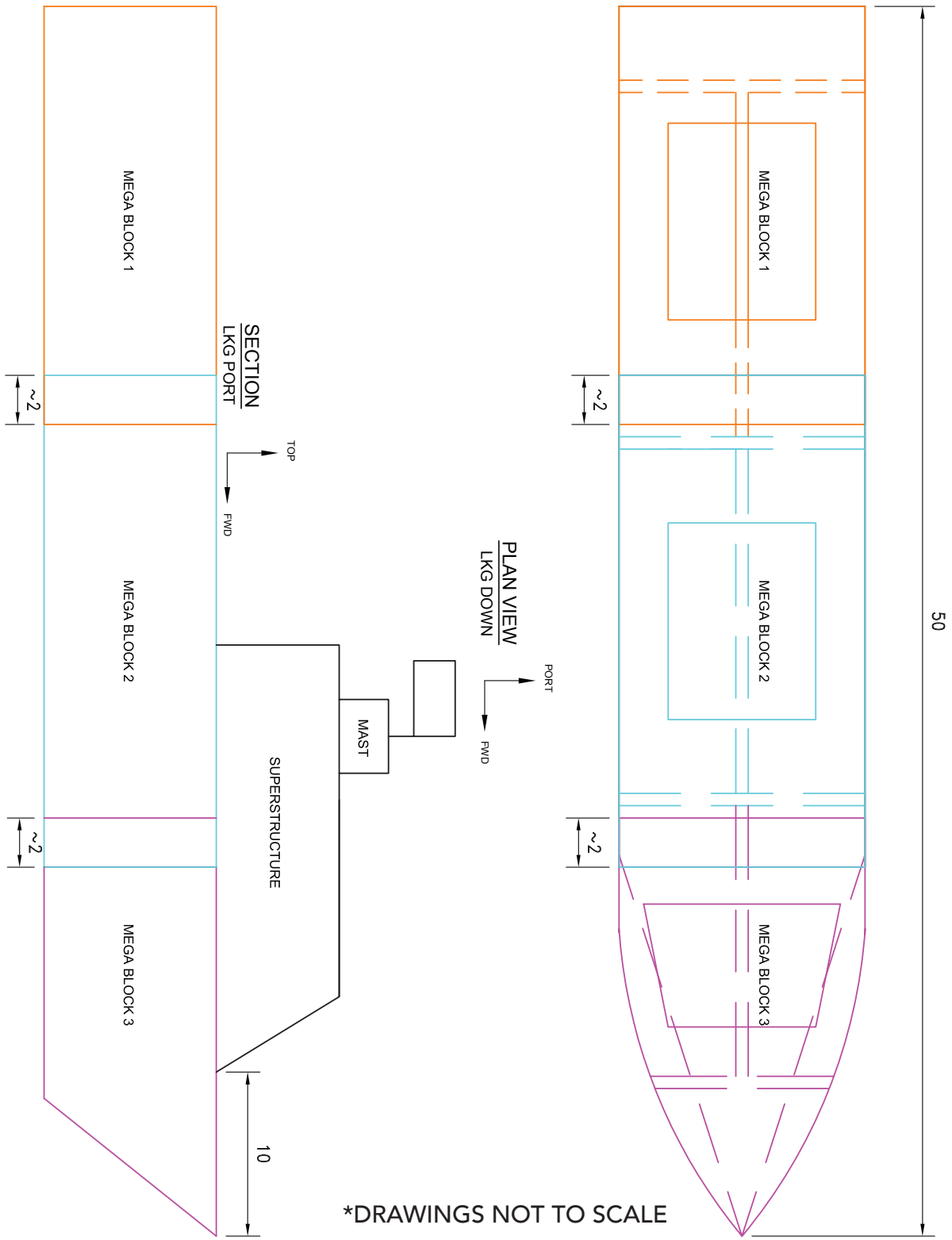

*DRAWINGS NOT TO SCALE

NOTES:

1. ALL DIMENSIONS IN CENTIMETERS
2. OVERLAP THE MEGA BLOCK SHELLS TO GET A FULL SHIP LENGTH OF 50CM
OVERLAP'S ARE APPROXIMATELY 2CM
3. MAY NEED TO TRIM DECKS AND OR LONGITUDINAL BULKHEADS TO FIT
MEGA BLOCKS TOGETHER
3. DO NOT GLUE THE SUPERSTRUCTURE ON, LIGHTLY TAPE IT. YOU WILL
NEED TO BE ABLE TO REMOVE THE SUPERSTRUCTURE TO ADD WEIGHT INSIDE

 STEM CLASS SHIP 1	ASSEMBLY DRAWING MEGA BLOCK JOIN SHIP 1				
	DWN	K. JACKMAN	CHK	C. BANKS	
	UNITS	CENTIMETRES	SCALE	NTS	SIZE D
	SHEET	1	DATE	2018-10-29	
	DWG NO	A01-MEGA BLOCK PACKAGE-001	REV	A	

© IRVING SHIPBUILDING INC. ALL RIGHTS RESERVED



To find out more about Irving Shipbuilding visit

ShipsforCanada.ca



 @IrvingShipbuild  IrvingShipbuilding  IrvingShipbuild